

# VISAGE SERIES

## IN-CEILING AND IN-WALL SPEAKERS



# VA-615DS

## IN-CEILING DUAL CHANNEL SPEAKER

The VA-615DS multi-purpose in-ceiling speaker combines the great performance of the VA-615 with the convenience of a multi-channel design. As a whole-house audio speaker, the dual-channel VA-615DS provides both left and right channels from one speaker for smaller rooms, or for budget-conscious installations. For home theater, the VA-615DS can be utilized as a di-/bi-polar surround speaker, providing an enveloping surround experience from its discreet location. For installations where surround speaker locations are highly limited, a pair of VA-615DS' can be positioned and configured to broadcast both the side- and rear-effects channels of a home theater system, allowing for a full 7.1 surround experience.

[SOLD THROUGH AUTHORIZED RBH DEALERS](#)

REDEFINING THE WAY YOU EXPERIENCE SOUND™



# SPECIFICATIONS

## MODEL NAME:

VA-615DS

## SERIES:

Visage Series

## SYSTEM TYPE:

In-ceiling 2-way Dual Channel Speaker

## FREQUENCY RESPONSE:

55Hz-20kHz ± 3dB

## SENSITIVITY:

90dB (2.83 Volts @ 1 Meter)

## RECOMMENDED POWER:

10-80 Watts

## DRIVE UNITS:

- (1) 6½" (165mm) PolyGraphite Cone Woofer
- (2) ¾" (19mm) Swivel Silk Dome Tweeter

## TWEETER PROTECTION:

Yes

## CROSSOVER FREQUENCY:

3,000 Hz

## CROSSOVER:

12dB/Octave

## IMPEDANCE:

8 Ohms x2

## CABINET:

Black Frame

## GRILLE:

Round Magnetic White Steel (Paintable)

## CUTOUT DIMENSIONS:

7-¾" (197mm) Dia.

## FINISHED DIMENSIONS:

Without Grille: 8-¾" Dia. x 3-7/8" D  
(222mm Dia. x 98mm D)

With Grille: 8-7/8" Dia. x 3-7/8" D  
(226mm Dia. x 98mm D)

## WEIGHT:

3.25 lbs. (1.48 kg)

## WARRANTY:

25 Years\*

# DIMENSIONS

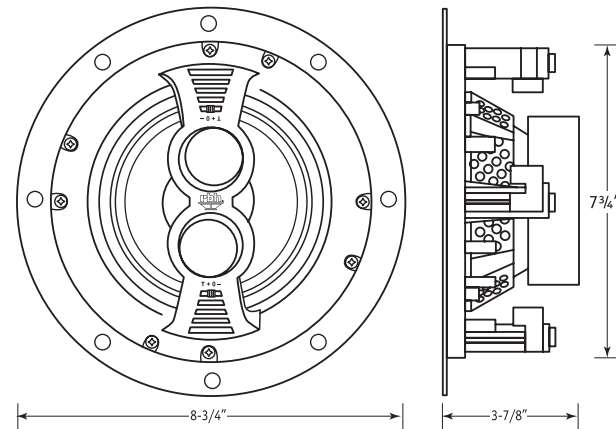

# FEATURES

- Visage Series in-ceiling speakers come with round, edge-to-edge magnetic grilles, but square grilles are also available separately.
- Swing out dog leg mounting system with pre-started screws for fast and easy installation.
- Polyswitch protection circuitry designed to protect the tweeter from being over driven.
- Dual sound contour switches allow the woofer and tweeter output levels to be customized for any room.
- Steep acoustic slope crossovers are used to integrate the drivers.
- Paintable grilles to allow the speakers to virtually hide in the ceiling.
- Installation template.

# ACCESSORIES

The below accessories are sold separately.

**Rear Enclosure:** FB-C6

**Back Can:** BC-6R (NOTE: can be used if modified)

**Blank Plate:** BP-6R

**Construction Bracket:** NCB-6R

**Speaker Grille Options:** Steel square white (except the VA-615L, VM-615L, VA-815L or VM-815L); stainless steel round or square in black or white.

*NOTE: Grille cut-away shown to highlight speaker details.*

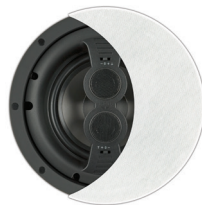

Round white grille included in package.



Round black grille sold separately.



Square white grille sold separately.



Square black grille sold separately.

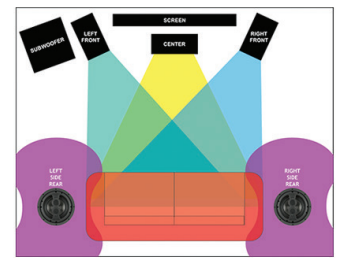

Bi-polar Layout

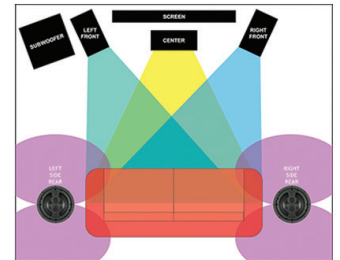

Di-polar Layout

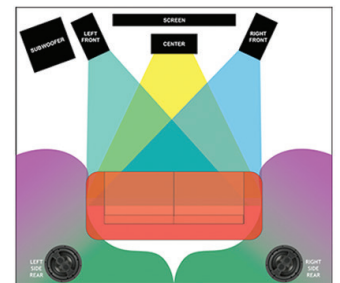

Dual Channel Layout

# MATCHING SERIES

## IN-CEILING SPEAKERS:

VA-607, VA-615, VA-615DS, VA-615L, VA-815, VA-815L, VF-615, VM-615, VM-615L, VM-815, VM-815L.

## IN-WALL SPEAKERS:

VA-414, VA-610, VM-414, VM-610, VM-616.



High Performance Home Audio  
Redefining the Way You Experience Sound™

382 Marshall Way, Ste. A,  
Layton, Utah, USA 84041

(800) 543-2205  
(801) 543-2200

Fax: (801) 543-3300  
<http://rbhsound.com>

\*Warranted for 25 (twenty-five) years from date of purchase to be free from defects and workmanship. For more information see your RBH dealer.

It is RBH Sound policy to continuously incorporate improvements into products; all specifications are subject to change without notice. For the most current information visit us online at <http://rbhsound.com>. Copyright © 2018 RBH Sound. All Rights Reserved.